

Introduction

This application note describes a unique implementation for the Intersil X9241 Digitally Controlled Potentiometers (XDCPs) in a process control or process monitoring environment. This implementation is made possible by some of the features of X9241, many of which have not been available on XDCP devices prior to the introduction of the X9241.

Implementation

Imagine a process control system or any other system where an analog voltage from a transducer needs to be monitored. The ideal method of monitoring such signals is to have an "alarm" in place for when the signal drifts out of its acceptable operating range, and to have the absolute value of the signal accessible to the processor so that intelligent decisions can be made about how to address the new condition. There are several ways of accomplishing this task using A-to-D converters, resistor-divider networks, or similar techniques, but these solutions prove to be messy and/or costly.

Imagine achieving the requirements of the ideal monitor with nothing more than a potentiometer and a comparator! The potentiometer is used to set a reference voltage which will become the trip point at which an "alarm" is generated (Figure 1). A simple comparator is used to compare the reference voltage to a transducer output voltage. The comparator output is then used to signal the processor by means of an interrupt. The missing element is the means to read the value of the transducer voltage. This can be done by implementing an A-to-D converter, but this adds cost and complexity. A variable voltage reference is still required, which the A-to-D converter cannot provide. By using the X9241 quad XDCP as the precision reference voltage potentiometer, the transducer voltage can be determined without adding any other components.

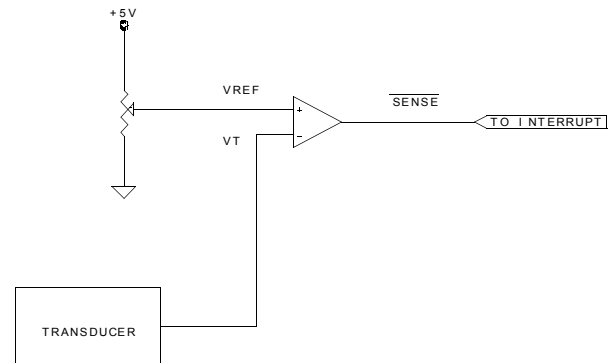

FIGURE 1.

The key to this scheme is a feature of the X9241 that allows direct reading of the contents of the Wiper Counter Registers (WCRs). Each of the four potentiometers on the X9241 has a WCR which contains the numeric position of the corresponding wiper. The processor can read the digital contents of the WCR via a 2-wire serial communications bus and, if necessary, easily calculate the actual wiper voltage. By adjusting the X9241 and reading the I/O bit assigned to the comparator output (after first disabling the interrupt), the XDCPs wiper voltage is matched to the transducer voltage, which can be determined by reading the contents of the WCR (Figure 2). The reference wiper setting (or the trip point setting) is not lost since it had previously been stored in one of the XDCPs four nonvolatile data registers (R0-R3). The contents of the desired data register can be transferred into the WCR by giving the appropriate software command. The interrupt is then enabled to resume monitoring.

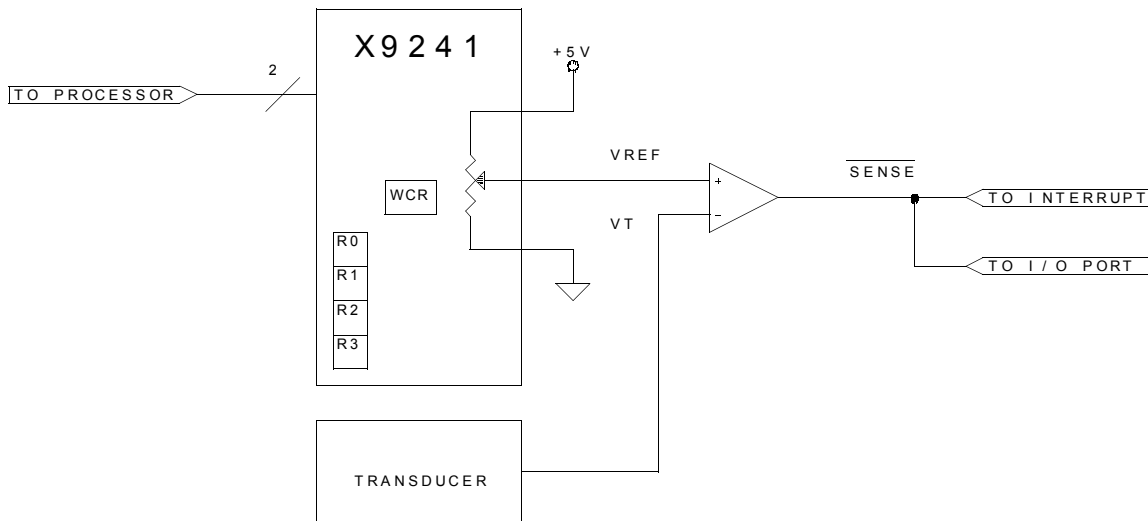

FIGURE 2. SMART MONITOR USING X9241 QUAD XDCP

System Calibration

Calibration of the transducer and A-to-D conversion process can be easily achieved by storing the required constants in system memory and having the system processor perform the appropriate calculation. In this manner the total system is calibrated rather than calibrating the transducer and A-to-D converter individually.

Reference Voltage Resolution

The X9241 consists of four potentiometers with 63 resistive elements each, giving each potentiometer 64 steps or wiper positions. The resolution would thus be 1/63 or approximately 1.59%. The X9241 feature set includes a cascade mode where adjacent potentiometers can be connected in series, and the extra wipers disabled, resulting in potentiometers of 127, 190, or 253 steps with internal wiper transitions, allowing resolution levels of 0.79%, 0.53%, or 0.40% respectively. If higher resolution is required, vernier cascading techniques can be used. (For a method of increasing resolution, see Intersil application note AN43 "Software Implements a High Resolution Nonvolatile Digital Potentiometer".)

Application Example

Let's say that a liquid or chemical used in a process must be at least +65°C for the process to yield the desired results. The reference voltage is initially calibrated by adjusting the XDCP, so that its wiper voltage is the next increment below the actual voltage of the transducer at +65°C. The WCR contents are then stored into the desired E2 register, (R0-

R3.) If the temperature of the liquid drops below +65°C, the comparator changes state and an interrupt is generated. The processor can then adjust the potentiometer until the comparator output changes state again, at which point the WCR contents can be read to find the new transducer voltage level. The processor can then make a decision about what has happened. If the temperature had drifted a couple of degrees below +65°C, then warming heaters can be switched on (or intensity increased) to return the liquid to +65°C. The process can then continue uninterrupted and the event can be logged into the system's EEPROM or NOVRAM memory for future analysis. However, if the voltage read indicates a temperature dramatically below +65°C, then the process can be shut down and the appropriate "alarm" activated. This monitor can easily be set-up to maintain an operating window, for example +65°C ±1°C, by using dual comparators.

Conclusion

The advanced features of the X9241, especially the direct read capability of the WCRs, allow the user to simplify monitor controls by having a device that functions both as a variable reference voltage and an A-to-D converter. Additionally, the X9241 allows total system calibration since correction factors may be stored in system memory and combined with the contents of the WCR as required for calibration. The 128-bits of nonvolatile memory in the data registers may be used for other purposes, if all four data registers are not required for use in transducer monitoring. The X9241 thus offers the user a simple, low cost, yet quite versatile solution for intelligent process monitoring and control.

Intersil Corporation reserves the right to make changes in circuit design, software and/or specifications at any time without notice. Accordingly, the reader is cautioned to verify that the Application Note or Technical Brief is current before proceeding.

For information regarding Intersil Corporation and its products, see www.intersil.com